



## SCOM-100 GSM Controller

### Advanced Irrigation System Control & Monitoring

Version: 1.0 – January 2012

#### Introduction

SCOM-100 is an SMS alarming & remote control unit with I/O expansion capability. It can fit a vast series of applications ranging from domestic to industrial. In order to use it all that is needed is a SIM card and a mobile phone.

It is desired to setup and operate an advanced irrigation system based on a Hunter technologies ICC irrigation controller and migrate an SCOM-100 unit to remotely manage the installation and receive alarms.

The system consists of:

- Water is supplied either or even both via a municipal link and a water well.
- Water supplied passes through a sand cyclone to purify it from sand & ground residues.
- A Subsidence Tank withholds all remaining water residues and fills 2 water tanks, 1.5 tn each, connected via appropriate piping.
- Level control on these tanks is performed via simple dielectric sensors.
- The water tanks are connected to a pump, which operates via a pressure switch and an electro valve.
- Pumped water is driven to sprinklers via respective electro valves.
- A Hunter ICC controller takes care of irrigation based on preset daily schedules.

An electric panel holds all automation elements needed and an SCOM-100 unit that is responsible for remote alarming, monitoring and control.

SCOM-100 can also as auxiliary unit, control and manage the irrigation remotely.

#### Measurements & Monitoring

- Measure temperature and receive alarms when limits are exceeded,
- Measure humidity and receive alarms for exceeding limits,
- Receive alarms whenever there is an automation related problem,
- Receive alarms whenever there is a power failure,
- Receive notifications when the system operated,
- Receive notifications that the system has failed to operate.

#### Security

Receive alarms whenever the pumping station door opens without a key.

#### Control

- Issue remote commands to configure seasonable irrigation schedules bypassing the Hunter ICC,
- Issue remote control commands to start the irrigation system on demand bypassing the Hunter ICC,
- Issue remote control commands to postpone an irrigation schedule on the Hunter ICC,
- Issue remote control commands to reset the system,
- Issue remote commands to configure setpoints and limits.
- Issue remote control commands to monitor current measurements and system status.

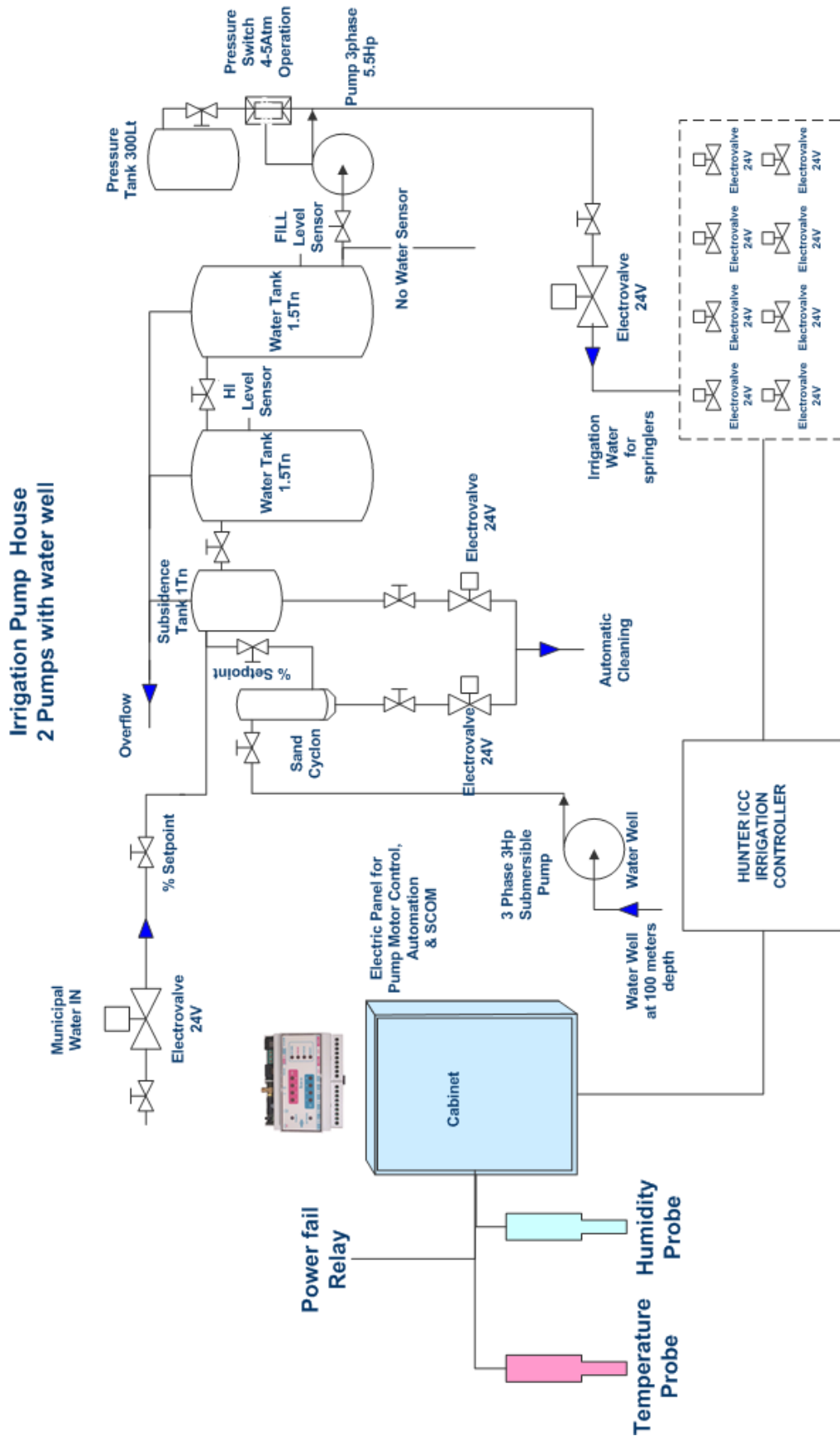

## System setup

Elements needed to set up such a system:

- An SCOM-100 controller
- A 12V DC power supply to power the SCOM-100
- A GSM antenna to attach on the SCOM-100
- A GSM SIM card to insert in the SCOM-100 unit
- A small plastic electric panel-cabinet to mount all the elements.
- A temperature probe (typically an AD592 temperature sensor)
- A humidity probe (typically a 5-95%, 4-20mA).
- A typical magnetic door contact to attach on a digital input of SCOM-100.
- A power loss detection relay to be attached at a digital input to monitor power failures.
- A series of relays to monitor pump thermal/magnetic protection switch, power asymmetry, no water conditions, water level, etc. These relay contacts should be connected to appropriate SCOM-100 digital inputs.

Additionally appropriate switches, relays and contacts can allow the user to configure the system for time scheduled lighting control and swimming pool monitoring & control.

## Functionality

SCOM-100 offers advanced features to create and manage daily and weekly schedules. A user can create seasonable schedules and remotely decide on which will be used from now on.

### Temperature

If the temperature rises above 30°C an SMS alarm will be issued to a list of recipients which can decide and decide on,

1. Increase the irrigation schedule,
2. Monitor the temperature and decide to issue remotely an immediate irrigation schedule,
3. Change the schedule by attaching and detaching an auxiliary schedule.

### Humidity

1. High levels which mean that it has rained can immediately restrict irrigation schedules to take effect.
2. Potential water leakage in the pump room can also be immediately alerted.

### Fire

Remotely instruct the irrigation system to start in case of a nearby fire.

### Power & automation management

1. Receive an alarm via SMS when there is a power failure.
2. Remotely start a power generator.
3. Remotely reset thermal/magnetic switches of pump motors.
4. Remotely issue commands to fill water tanks.
5. Remotely reset the system.
6. Automatically control irrigation electro valves.
7. Extend the SCOM-100 unit with an AI expansion unit and also measure the quality of power e.g. voltage, current, frequency.

## Advanced Functionality

1. Automatically engage and disengage the irrigation system during change of seasons or high rain seasons.

2. Monitor online the system from everywhere.
3. Issue remote commands to configure the entire system from a mobile phone.

Note: A single SCOM-100 unit, which has by default 2 analogue inputs, 4 digital inputs, and 4 relay digital outputs can manage all the above. The SCOM-100 can be extended for more digital inputs and outputs, more analogue sensors using extension units.